

ЭЛЕКТРУМ АВ

Паспорт (eng)

Реле постоянного тока

С трансформаторной изоляцией

По вопросам продаж и поддержки обращайтесь:

Архангельск +7 (8182) 45-71-35
Астрахань +7 (8512) 99-46-80
Барнаул +7 (3852) 37-96-76
Белгород +7 (4722) 20-58-80
Брянск +7 (4832) 32-17-25
Владивосток +7 (4232) 49-26-85
Волгоград +7 (8442) 45-94-42
Екатеринбург +7 (343) 302-14-75
Ижевск +7 (3412) 20-90-75
Казань +7 (843) 207-19-05
Калуга +7 (4842) 33-35-03

Кемерово +7 (3842) 21-56-70
Киров +7 (8332) 20-58-70
Краснодар +7 (861) 238-86-59
Красноярск +7 (391) 989-82-67
Курск +7 (4712) 23-80-45
Липецк +7 (4742) 20-01-75
Магнитогорск +7 (3519) 51-02-81
Москва +7 (499) 404-24-72
Мурманск +7 (8152) 65-52-70
Наб.Челны +7 (8552) 91-01-32
Ниж.Новгород +7 (831) 200-34-65

Новосибирск +7 (383) 235-95-48
Омск +7 (381) 299-16-70
Орел +7 (4862) 22-23-86
Оренбург +7 (3532) 48-64-35
Пенза +7 (8412) 23-52-98
Пермь +7 (342) 233-81-65
Ростов-на-Дону +7 (863) 309-14-65
Рязань +7 (4912) 77-61-95
Самара +7 (846) 219-28-25
Санкт-Петербург +7 (812) 660-57-09
Саратов +7 (845) 239-86-35

Сочи +7 (862) 279-22-65
Ставрополь +7 (8652) 57-76-63
Сургут +7 (3462) 77-96-35
Тверь +7 (4822) 39-50-56
Томск +7 (3822) 48-95-05
Тула +7 (4872) 44-05-30
Тюмень +7 (3452) 56-94-75
Ульяновск +7 (8422) 42-51-95
Уфа +7 (347) 258-82-65
Хабаровск +7 (421) 292-95-69
Челябинск +7 (351) 277-89-65
Ярославль +7 (4852) 67-02-35

сайт: electrum.pro-solution.ru | эл. почта: emt@pro-solution.ru
телефон: 8 800 511 88 70

1. APPLICATION AND PRODUCED MODULES

Modules for DC commutation (semiconductor normally opened unipolar relay with transformer decoupling with low current and low switch-on time) of types MT14, MT15D, MT14PT, MT15PT are intended to use in automatics devices as a commutating element with maximum peak voltage up to 1200 V and DC up to 400 A. The modules for DC commutation (hereinafter modules) are represented with the following versions:

MT14A – a module based on MOSFET-transistor shunted with a reverse fast-recovery diode with control voltage 4...10 V.

MT14B – a module based on MOSFET-transistor shunted with a reverse fast-recovery diode with control voltage 10...30 V.

By the power switch types the modules MT14A(B) are represented with the following versions (specified maximum permissible values of currents and voltages):

Peak voltage 60 V with an amount of DC 10,20,40,60,80,120,200,240,300,400 A.

Peak voltage 100 V with an amount of DC 5,10,20,40,60,80,120,160,200,240,300,400 A.

Peak voltage 200 V with an amount of DC 5,10,20,30,40,60,80,120,160,200,240,320,400 A.

Peak voltage 250 V with an amount of DC 5,10,20,40,60,80,120,160,200,240 A.

MT15DA – a module based on IGBT-transistor shunted with a reverse fast-recovery diode with control voltage 4...10 V.

MT15DB – a module based on IGBT-transistor shunted with a reverse fast-recovery diode with control voltage 10...30 V.

By types of power switch the modules of MT15DA(B) are represented with following versions (specified maximum permissible values of currents and voltages):

Peak voltage 600 V with an amount of DC 5,10,20,30,40,60,80,120,160,180,240,300 A.

Peak voltage 1200 V with an amount of DC 5,10,20,40,60,80,120,160,180,240,300 A.

MT14PTA – a module based on MOSFET-transistor shunted with a reverse fast-recovery diode with control voltage 4...10 V, with inbuilt protections against overvoltage and current overload.

MT14PTB – a module based on MOSFET-transistor shunted with a reverse fast-recovery diode with control voltage 10...30 V, with inbuilt protections against overvoltage and current overload.

By types of power switch the modules of MT14PTA(B) are represented with following versions (specified maximum permissible values of currents and voltages):

Peak voltage 40 V with an amount of DC 10,20,60,90,120,150,240,320,400 A.

Peak voltage 60 V with an amount of DC 10,20,60,90,120,150,240,320,400 A.

Peak voltage 100 V with an amount of DC 5,10,20,40,60,90,120,150,180,240,320 A.

Peak voltage 200 V with an amount of DC 5,10,20,60,90,120,150,180,240 A.

Peak voltage 250 V with an amount of DC 5,10,20,30,40,50,60,90,120,150,180 A.

MT15PTA – a module based on IGBT-transistor shunted with a reverse fast-recovery diode with control voltage 4...10 V, with inbuilt protections against overvoltage and current overload.

MT15PTB – a module based on IGBT-transistor shunted with a reverse fast-recovery diode with control voltage 10...30 V, with inbuilt protections against overvoltage and current overload.

By types of power switch the modules MT15PTA(B) are represented with the following versions (specified maximum permissible values of currents and voltages):

Peak voltage 600 V with an amount of current 5,10,20,30,40,50,60,75,90,120,150,180,240 A.

Peak voltage 1200 V with an amount of current 5,10,20,30,40,50,60,75,90,120,150,180,240 A.

Depending on the current and version the modules MO16 are produced in the versions that are represented in Table 1.1. The modules are produced only in the versions where at crossing the class line (peak voltage of power switch, maximum permissible one) of the module and the current column is specified the overall dimension corresponding to the version.

Table 1.1 – Produced modules MT14, 15 and corresponding to them overall dimensions

Type	Class	Current, A																			
		5	10	20	30	40	50	60	75	80	90	120	150	160	180	200	240	300	320	400	
MT14	0,6		6.1	6.1		6.1		6.1		6.1		6.2				6.3	6.3	6.4		6.4	
	1	6.1	6.1	6.1		6.1		6.1		6.1		6.2		6.2		6.3	6.3	6.4		6.4	
	2	6.1	6.1	6.1	6.1	6.1		6.1		6.1		6.2		6.2		6.3	6.3		6.4	6.4	
	2,5	6.1	6.1	6.1		6.1		6.2		6.2		6.2		6.2		6.3	6.3				
MT15D	6	6.1	6.1	6.1	6.1	6.1		6.1		6.2		6.2		6.3	6.3		6.3	6.4			
	12	6.1	6.1	6.1		6.1		6.1		6.2		6.2		6.3	6.3		6.3	6.4			
MT14PT	0,4		6.5	6.5				6.5			6.5	6.6	6.6					6.7		6.8	6.8
	0,6		6.5	6.5				6.5			6.5	6.6	6.6					6.7		6.8	6.8
	1	6.5	6.5	6.5		6.5		6.5			6.6	6.6	6.6		6.7			6.7		6.8	
	2	6.5	6.5	6.5				6.6			6.6	6.6	6.7		6.7			6.7			
	2,5	6.5	6.5	6.5	6.5	6.6	6.6	6.6			6.6	6.6	6.6		6.7						
MT15PT	6	6.5	6.5	6.5	6.5	6.5	6.5	6.6	6.6		6.6	6.6	6.6		6.7			6.7			
	12	6.5	6.5	6.5	6.5	6.5	6.6	6.6	6.6		6.6	6.6	6.6		6.7			6.7			

On Figure 1.1 is shown modules' names explanation.

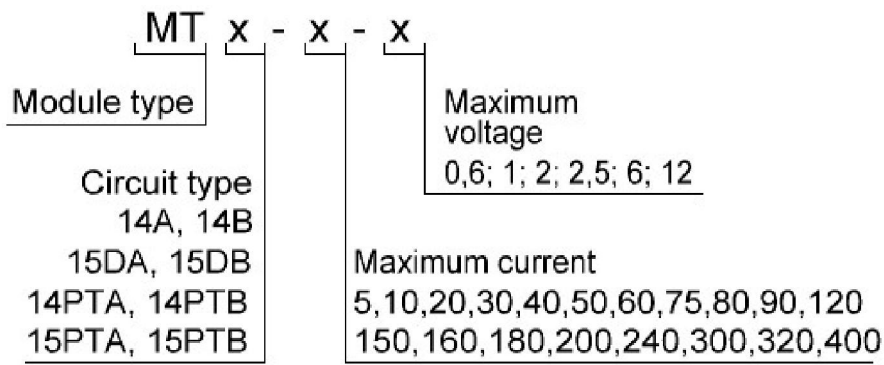

Figure 1.1 – Modules names explanation

For example, module MT15DA-80-12: a module with control voltage 4...10 V, with maximum permissible collector-emitter voltage 1200 V and maximum DC 80 A.

2. GENERAL DESCRIPTION

The modules MT14, MT15B don't have any inbuilt protections; the relays operate only in accordance with the control signal.

The modules MT14(15)PTA and MT14(15)PTB have inbuilt protections against overvoltage and current overload. The overvoltage protection is represented with a Zener diode installed in parallel with collector-gate circuit; when increasing the voltage (in collector-emitter circuit) set by the threshold Zener diode the power voltage opens up the transistor, thereby loading the circuit and decreasing voltage surge amplitude.

Current overload protection is represented with represented by a current collector resistor installed in the power circuit, with a comparison circuit and a reset circuit. When the current exceeds the set threshold during longer than 10 μs the control circuit closes the transistor for 5...20 ms (it depends on the value of overcurrent), after that the transistor opens again and if overload wasn't eliminated then the protection cycle repeats.

Functional circuits combined with switching circuits of modules MT14, 15 are represented on Figures 2.1 - 2.8.

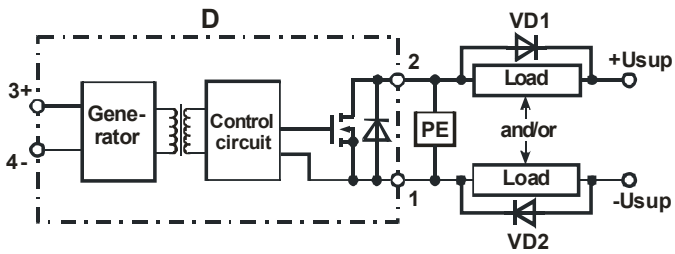

Figure 2.1 – Functional circuit of MT14 (figure 6.1)

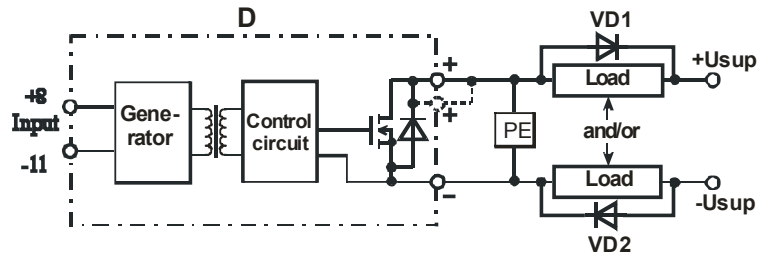

Figure 2.2 – Functional circuit of MT14 (figure 6.2,3,4)

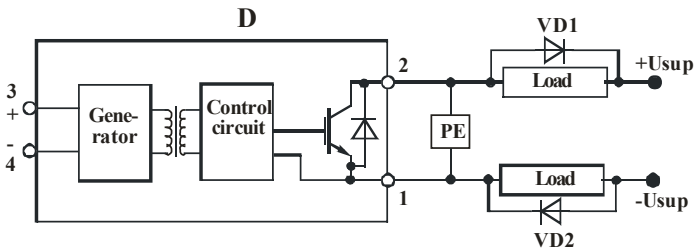

Figure 2.3 – Functional circuit of MT15D (figure 6.1)

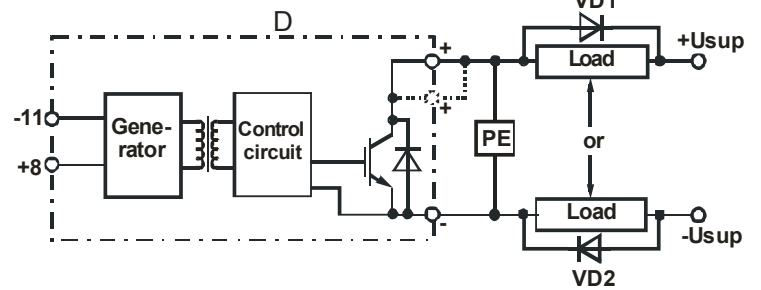

Figure 2.4 – Functional circuit of MT15D (figure 6.2,3,4)

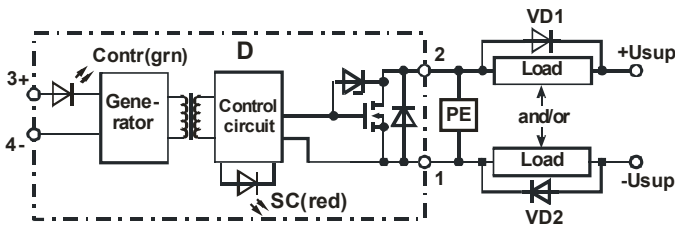

Figure 2.5 – Functional circuit of MT14PT (figure 6.5)

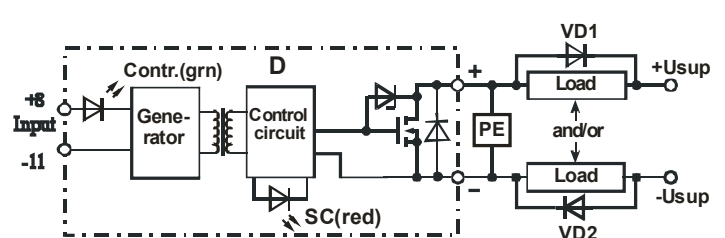

Figure 2.6 – Functional circuit of MT14PT (figure 6.6,7,8)

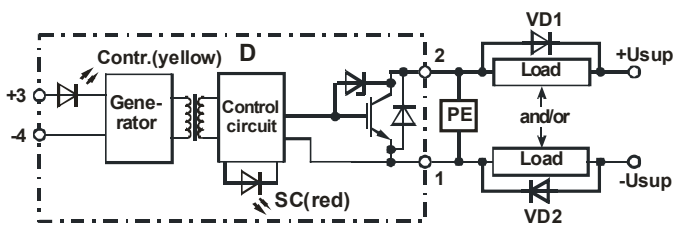

Figure 2.7 – Functional circuit of MT15PT (figure 6.1)

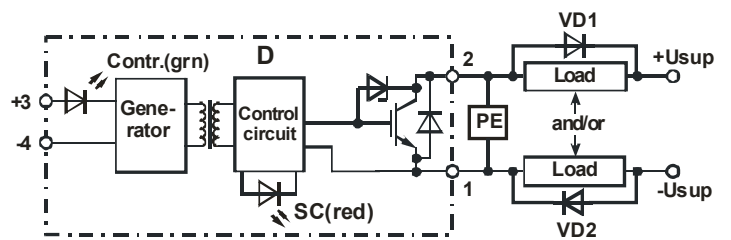

Figure 2.8 – Functional circuit of MT15PT (figure 6.6,7,8)

Where D – module; PE – protection element; VD1,VD2 – diodes (are installed at inductive load); B – active protection unit (provides voltage limitation on transistor drain (collector) on level that not higher than U_{lim}).

3. BASIC PARAMETERS

Basic parameters and maximum permissible parameters of the modules at temperature 25°C are shown in Tables 3.1 – 3.16.

Table 3.1 – Basic and maximum permissible parameters of control of modules MT14, 15

Parameter name, unit	Symbol	MT14	MT15D	MT14PT	MT15PT
Input current of ver. «A» at $U_{IH} = 4$ V (max), mA	I_{IN}	7	7	50	25
Input current of ver. «A» at $U_{IH} = 10$ V (max), mA		15	15	60	30
Input current of ver. «B» at $U_{IH} = 10$ V (max), mA		15	15	30	30
Input current of ver. «B» at $U_{IH} = 30$ V (max), mA		20	20	40	40
Switch-on voltage of ver. «A», V	U_{IH}	4...10			
Switch-on voltage of ver. «B», V		10...30			
Switch-off voltage of ver. «A», V	U_{IL}	-3.5...0.8			
Switch-off voltage of ver. «B», V		-3.5...0.8			
On / off duration (max), μ s	$t_{on/off}$	50 / 50	50 / 50	100 / 100	100 / 100

Table 3.2 – Basic parameters of protections of modules MT14PT, MT15PT

Parameter name, unit	Symbol	Value	Notes
Current protection operation delay (max), μ s	$t_{d(SC)}$	10	
Blocking duration when operating of current protection (typ.), ms	$t_{B(SC)}$	20	
Current of protection operation against current overload (typ.), A	I_{SC}	For modules with maximum current:	
		7.5	5
		15	10
		30	20
		45	30
		60	40
		75	50
		90	60
		112	75
		135	90
		180	120
		225	150
		270	180
360	240		
480	320		
600	400		
Voltage of protection operation against overvoltage (typ.), V	U_{AC}	For modules with class:	
		36	0,4
		48	0,6
		80	1
		145	2
		200	2,5
		480	6
800	12		

Table 3.3 – Basic and maximum permissible parameters of modules of 0,4 class – up to 90 A

Parameter name, unit	Symbol	Current, A			
		10	20	60	90
Drain-source voltage (max), V	V_{DSS}	40			
Direct voltage of power circuit (max), V	V_{DC}	22			
DC of power circuit (max), A	I_{DC}	10	20	60	90
Pulse current of power circuit (max), A	I_P	30	60	180	270
Drain-source resistance in open state (max), m Ω	$R_{DS(on)}$	10.5	10.5	1.6	1.6
Direct voltage fall on reverse diode (max), V	V_F	1.3			
Leakage current of power switch (max), μ A	I_{DSS}	50			
Junction temperature (max), $^{\circ}$ C	T_j	150			
Junction-base thermal resistance (max), $^{\circ}$ C/W	$R_{th(j-a)}$	2.7	1.6	1.0	0.7
Insulation strength, (DC), V	V_{ISOL}	1000			

Table 3.4 – Basic and maximum permissible parameters of modules of 0,4 class – up to 400 A

Parameter name, unit	Symbol	Current, A				
		120	150	240	320	400
Drain-source voltage (max), V	V_{DSS}	60				
Direct voltage of power circuit (max), V	V_{DC}	22				
DC of power circuit (max), A	I_{DC}	120	150	240	320	400
Pulse current of power circuit (max), A	I_P	360	450	720	960	1200
Drain-source resistance in open state (max), m Ω	$R_{DS(on)}$	1.83	1.83	1.1	0.8	0.4
Direct voltage fall on reverse diode (max), V	V_F	1.3				
Leakage current of power switch (max), μ A	I_{DSS}	50				
Junction temperature (max), $^{\circ}$ C	T_j	150				
Junction-base thermal resistance (max), $^{\circ}$ C/W	$R_{th(j-a)}$	0.5	0.35	0.25	0.2	0.15
Insulation strength, (DC), V	V_{ISOL}	1000				

Table 3.5 – Basic and maximum permissible parameters of modules of 0,6 class – up to 80 A

Parameter name, unit	Symbol	Current, A				
		10	20	40	60	80
Drain-source voltage (max), V	V_{DSS}	60				
Direct voltage of power circuit (max), V	V_{DC}	35				
DC of power circuit (max), A	I_{DC}	10	20	40	60	80
Pulse current of power circuit (max), A	I_P	30	60	120	180	240
Drain-source resistance in open state (max), m Ω	$R_{DS(on)}$	60	28	12	3	6
Direct voltage fall on reverse diode (max), V	V_F	1.3				
Leakage current of power switch (max), μ A	I_{DSS}	50				
Junction temperature (max), $^{\circ}$ C	T_j	150				
Junction-base thermal resistance (max), $^{\circ}$ C/W	$R_{th(j-a)}$	2.7	1.6	1.0	0.7	0.5
Insulation strength, (DC), V	V_{ISOL}	1000				

Table 3.6 – Basic and maximum permissible parameters of modules of 0,6 class – up to 400 A

Parameter name, unit	Symbol	Current, A				
		120	200	240	300	400
Drain-source voltage (max), V	V_{DSS}	60				
Direct voltage of power circuit (max), V	V_{DC}	35				
DC of power circuit (max), A	I_{DC}	120	200	240	300	400
Pulse current of power circuit (max), A	I_P	360	600	720	900	1200
Drain-source resistance in open state (max), mΩ	$R_{DS(on)}$	1.5	1.0	0.75	0.6	0.5
Direct voltage fall on reverse diode (max), V	V_F	1.3				
Leakage current of power switch (max), μA	I_{DSS}	200				
Junction temperature (max), °C	T_j	150				
Junction-base thermal resistance (max), °C/W	$R_{th(j-a)}$	0.35	0.25	0.2	0.15	0.12
Insulation strength, (DC), V	V_{ISOL}	1000				

Table 3.7 – Basic and maximum permissible parameters of modules of 1 class – up to 80 A

Parameter name, unit	Symbol	Current, A					
		5	10	20	40	60	80
Drain-source voltage (max), V	V_{DSS}	100					
Direct voltage of power circuit (max), V	V_{DC}	60					
DC of power circuit (max), A	I_{DC}	5	10	20	40	60	80
Pulse current of power circuit (max), A	I_P	15	30	60	120	180	240
Drain-source resistance in open state (max), mΩ	$R_{DS(on)}$	200	120	55	27	20	14
Direct voltage fall on reverse diode (max), V	V_F	1.3					
Leakage current of power switch (max), μA	I_{DSS}	50					
Junction temperature (max), °C	T_j	150					
Junction-base thermal resistance (max), °C/W	$R_{th(j-a)}$	3.3	2.1	1.3	0.9	0.6	0.5
Insulation strength, (DC), V	V_{ISOL}	1000					

Table 3.8 – Basic and maximum permissible parameters of modules of 1 class – up to 400 A

Parameter name, unit	Symbol	Current, A					
		120	160	200	240	300	400
Drain-source voltage (max), V	V_{DSS}	100					
Direct voltage of power circuit (max), V	V_{DC}	60					
DC of power circuit (max), A	I_{DC}	120	160	200	240	300	400
Pulse current of power circuit (max), A	I_P	360	480	600	720	900	1200
Drain-source resistance in open state (max), mΩ	$R_{DS(on)}$	8	6	5	4	2.5	1.8
Direct voltage fall on reverse diode (max), V	V_F	1.3					
Leakage current of power switch (max), μA	I_{DSS}	200					
Junction temperature (max), °C	T_j	150					
Junction-base thermal resistance (max), °C/W	$R_{th(j-a)}$	0.3	0.23	0.18	0.16	0.15	0.12
Insulation strength, (DC), V	V_{ISOL}	1000					

Table 3.9 – Basic and maximum permissible parameters of modules of 2 class – up to 80 A

Parameter name, unit	Symbol	Current, A					
		5	10	20	40	60	80
Drain-source voltage (max), V	V_{DSS}	200					
Direct voltage of power circuit (max), V	V_{DC}	130					
DC of power circuit (max), A	I_{DC}	5	10	20	40	60	80
Pulse current of power circuit (max), A	I_P	15	30	60	120	180	240
Drain-source resistance in open state (max), m Ω	$R_{DS(on)}$	300	180	85	30	25	15
Direct voltage fall on reverse diode (max), V	V_F	1.3					
Leakage current of power switch (max), μ A	I_{DSS}	50					
Junction temperature (max), $^{\circ}$ C	T_j	150					
Junction-base thermal resistance (max), $^{\circ}$ C/W	$R_{th(j-a)}$	2.0	1.2	0.9	0.6	0.45	0.31
Insulation strength, (DC), V	V_{ISOL}	1000					

Table 3.10 – Basic and maximum permissible parameters of modules of 2 class – up to 400 A

Parameter name, unit	Symbol	Current, A					
		120	160	200	240	300	400
Drain-source voltage (max), V	V_{DSS}	200					
Direct voltage of power circuit (max), V	V_{DC}	130					
DC of power circuit (max), A	I_{DC}	120	160	200	240	300	400
Pulse current of power circuit (max), A	I_P	360	480	600	720	900	1200
Drain-source resistance in open state (max), m Ω	$R_{DS(on)}$	9	7	5.5	4.5	3.5	2.8
Direct voltage fall on reverse diode (max), V	V_F	1.3					
Leakage current of power switch (max), μ A	I_{DSS}	200					
Junction temperature (max), $^{\circ}$ C	T_j	150					
Junction-base thermal resistance (max), $^{\circ}$ C/W	$R_{th(j-a)}$	0.25	0.18	0.14	0.12	0.09	0.07
Insulation strength, (DC), V	V_{ISOL}	1000					

Table 3.11 – Basic and maximum permissible parameters of modules 2,5 class – up to 80 A

Parameter name, unit	Symbol	Current, A					
		5	10	20	40	60	80
Drain-source voltage (max), V	V_{DSS}	250					
Direct voltage of power circuit (max), V	V_{DC}	170					
DC of power circuit (max), A	I_{DC}	5	10	20	40	60	80
Pulse current of power circuit (max), A	I_P	15	30	60	120	180	240
Drain-source resistance in open state (max), m Ω	$R_{DS(on)}$	280	140	75	30	25	15
Direct voltage fall on reverse diode (max), V	V_F	1.3					
Leakage current of power switch (max), μ A	I_{DSS}	50					
Junction temperature (max), $^{\circ}$ C	T_j	150					
Junction-base thermal resistance (max), $^{\circ}$ C/W	$R_{th(j-a)}$	1.0	0.8	0.6	0.5	0.26	0.2
Insulation strength, (DC), V	V_{ISOL}	1000					

Table 3.12 – Basic and maximum permissible parameters of modules of 2,5 class – up to 240 A

Parameter name, unit	Symbol	Current, A			
		120	160	200	240
Drain-source voltage (max), V	V_{DSS}	250			
Direct voltage of power circuit (max), V	V_{DC}	170			
DC of power circuit (max), A	I_{DC}	120	160	200	240
Pulse current of power circuit (max), A	I_P	360	480	600	720
Drain-source resistance in open state (max), m Ω	$R_{DS(on)}$	10	7.5	6	5
Direct voltage fall on reverse diode (max), V	V_F	1.3			
Leakage current of power switch (max), μ A	I_{DSS}	200			
Junction temperature (max), $^{\circ}$ C	T_j	150			
Junction-base thermal resistance (max), $^{\circ}$ C/W	$R_{th(j-a)}$	0.17	0.13	0.1	0.09
Insulation strength, (DC), V	V_{ISOL}	1000			

Table 3.13 – Basic and maximum permissible parameters of modules of 6 class – up to 60 A

Parameter name, unit	Symbol	Current, A					
		5	10	20	30	40	60
Drain-source voltage (max), V	V_{CES}	600					
Direct voltage of power circuit (max), V	V_{DC}	350					
DC of power circuit (max), A	I_{DC}	5	10	20	30	40	60
Pulse current of power circuit (max), A	I_P	15	30	60	90	120	180
Drain-source resistance in open state (max), m Ω	$V_{CE(on)}$	3.0					
Direct voltage fall on reverse diode (max), V	V_F	2.5					
Leakage current of power switch (max), μ A	I_{CES}	500					
Junction temperature (max), $^{\circ}$ C	T_j	150					
Junction-base thermal resistance (max), $^{\circ}$ C/W	$R_{th(j-a)}$	1.6	1.5	1.4	0.75	0.7	0.5
Insulation strength, (DC), V	V_{ISOL}	4000					

Table 3.14 – Basic and maximum permissible parameters of modules of 6 class – up to 300 A

Parameter name, unit	Symbol	Current, A					
		80	120	160	200	240	300
Drain-source voltage (max), V	V_{CES}	600					
Direct voltage of power circuit (max), V	V_{DC}	350					
DC of power circuit (max), A	I_{DC}	80	120	160	200	240	300
Pulse current of power circuit (max), A	I_P	240	360	480	600	720	900
Drain-source resistance in open state (max), m Ω	$V_{CE(on)}$	3.0					
Direct voltage fall on reverse diode (max), V	V_F	2.5					
Leakage current of power switch (max), μ A	I_{CES}	3000					
Junction temperature (max), $^{\circ}$ C	T_j	150					
Junction-base thermal resistance (max), $^{\circ}$ C/W	$R_{th(j-a)}$	0.25	0.18	0.13	0.11	0.09	0.07
Insulation strength, (DC), V	V_{ISOL}	4000					

Table 3.15 – Basic and maximum permissible parameters of modules of 12 class – up to 60 A

Parameter name, unit	Symbol	Current, A					
		5	10	20	30	40	60
Drain-source voltage (max), V	V_{CES}	1200					
Direct voltage of power circuit (max), V	V_{DC}	650					
DC of power circuit (max), A	I_{DC}	5	10	20	30	40	60
Pulse current of power circuit (max), A	I_P	15	30	60	90	120	180
Drain-source resistance in open state (max), m Ω	$V_{CE(on)}$	3.0					
Direct voltage fall on reverse diode (max), V	V_F	2.5					
Leakage current of power switch (max), μ A	I_{CES}	500					
Junction temperature (max), $^{\circ}$ C	T_j	150					
Junction-base thermal resistance (max), $^{\circ}$ C/W	$R_{th(j-a)}$	2.3	1.4	0.8	0.6	0.5	0.4
Insulation strength, (DC), V	V_{ISOL}	4000					

Table 3.16 – Basic and maximum permissible parameters of modules of 12 class – up to 300 A

Parameter name, unit	Symbol	Current, A					
		80	120	160	200	240	300
Drain-source voltage (max), V	V_{CES}	1200					
Direct voltage of power circuit (max), V	V_{DC}	650					
DC of power circuit (max), A	I_{DC}	80	120	160	200	240	300
Pulse current of power circuit (max), A	I_P	240	360	480	600	720	900
Drain-source resistance in open state (max), m Ω	$V_{CE(on)}$	3.0					
Direct voltage fall on reverse diode (max), V	V_F	2.5					
Leakage current of power switch (max), μ A	I_{CES}	3000					
Junction temperature (max), $^{\circ}$ C	T_j	150					
Junction-base thermal resistance (max), $^{\circ}$ C/W	$R_{th(j-a)}$	0.26	0.18	0.13	0.11	0.09	0.07
Insulation strength, (DC), V	V_{ISOL}	4000					

4. INSTRUCTIONS FOR USE

General requirements

It is recommended to operate the module at operating value of the average current not more than 80% from specified one in the name of the module and the junction temperature not more than (70÷80)% from the maximum one.

It is not allowed to operate the module in modes at simultaneous influence of two or more maximum permissible values.

In the electric circuit of equipment with using of the modules should be provided the fast-speed protection against prohibitive overloads, SCs and commutating overloads.

Module mounting

The module is mounted in the equipment to cooler (chassis, application housing, metal plates, etc.) in any orientation with screws M4 with torque (5±0.5) N·m, with obligatory installation of flat and spring washers. The module should be located in such a way to protect it against additional heat from neighbor elements. The planes of cooler ribs should be oriented in the direction of air flow.

The contact area of the cooler should have roughness not more than 2.5 μ m and flatness tolerance – not more than 30 μ m. Cooler surface should not have any rough edges, honeycombs. There should not be extraneous particles between the module and cooler. To improve the heat balance the module installation to mounting area or cooler should be carried out by instrumentality of heat conducting pastes or having similar heat conducting properties.

When mounting, you should provide uniform pressure of module housing to cooler. For this purpose you should tighten all screws uniform in 2 – 4 steps by turns: first, located on one diagonal, then on the other one. When dismounting the module the screw tightening should be done in the reverse order.

Not earlier than in 3 hours after mounting the screws should be rotated to the end, keeping the prescribed torque, because the part of heat conducting paste under pressure will outflow and the fastening can fail.

You can mount the several modules without additional insulating spacer to one cooler, on condition that voltage between outputs of different modules will not exceed the minimum value of isolation breakdown voltage of each of them or when cooler is grounded.

Connection to module

Electric wires and cables will be connected to power contacts of the module by means of screws M6 or M5 with torque (4 ± 0.5) N·m or by means of bolts M8 or M10 with torque (5 ± 0.5) N·m and the washers that are supplied in the package.

Power wires should be connected by means of connectors with corrosion-inhibiting cover, which are purified of foreign layers. When the screws (bolts) are tightened it is recommended to fasten the connection with paint. It is recommended to tighten screws (bolts) repeatedly in 8 days and in 6 weeks after the start of operating. Afterwards tightening should be controlled at least once a half year.

The controlling module outputs (gate and control source output) are intended for mounting by means of soldering or split connectors. Permissible number of module outputs' re-soldering during electronic (assembly) edit is three. Outputs soldering should be performed at temperature not higher than (235 ± 5) °C. Soldering duration is not longer than 3 sec.

When mounting and operating it is necessary to make protection measures against static electricity impact and overvoltage in gate circuit; on mounting personnel should use a ground band and grounded low-voltage soldering irons with transformer supply.

Operation requirements

The module should be used under mechanical loads in accordance with Table 4.1.

Table 4.1 – Mechanical loads impact

External exposure factor	External exposure factor value
Sinusoidal vibration: - acceleration, m/s^2 (g); - frequency, Hz	150 (15) 0.5 - 100
Multiple-acting mechanic shock: - peak shock acceleration, m/s^2 (g); - shock acceleration duration, ms	40 (4) 50
Linear acceleration, m/s^2 (g)	5000 (500)

The module should be used under climatic loads in accordance with Table 4.2.

Table 4.2 – Climatic loads impact

Climatic factor	Climatic factor value
Reduced ambient temperature: - operating, °C; - maximum, °C	- 40 - 45
High ambient temperature: - operating, °C; - maximum, °C	+ 85 + 100
Relative humidity at temperature 35 °C without moisture condensation, %, max	98

Safety requirements

1. Working with the module should only be performed by qualified personnel.
2. Do not touch the power terminals of the module when applying a voltage.
3. Do not connect or disconnect wires and connectors while the power to the circuit module is applying a voltage.
4. Do not touch the module radiator, if it is not grounded in and is applying a voltage on it.

5. Do not touch the cooler and the module housing during its operation, since their temperature can be very high.
6. Immediately turn off the power supply of the module if it discharges smoke, odor or abnormal noises, check if the module correctly connected.
7. It is not allowed to penetrate water and other liquids to the module.

5. RELIABILITY REQUIREMENTS

The manufacturer guarantees the quality of the module all the requirements of the passport if the consumer observes terms and conditions of storage, installation and operation, as well as guidance on the application specified in the user's manual.

Operating warranty is two years from the acceptance date, in case of requalification – from the date of the requalification.

Reliability probability of the module for 25000 hours must be at least 0.95.

Gamma percentage life (T_γ) of module at $\gamma = 90\%$ in typical operation conditions should not be less than 50 000 hours within lifetime.

Gamma-percent service life of the modules, subject to cumulative operating time is not more than gamma-percent life, not less than 10 years, at $\gamma = 90\%$.

Gamma-percent storageability time of the modules, at $\gamma = 90\%$ and storing – 10 years.

6. OVERALL AND CONNECTING DIMENSIONS

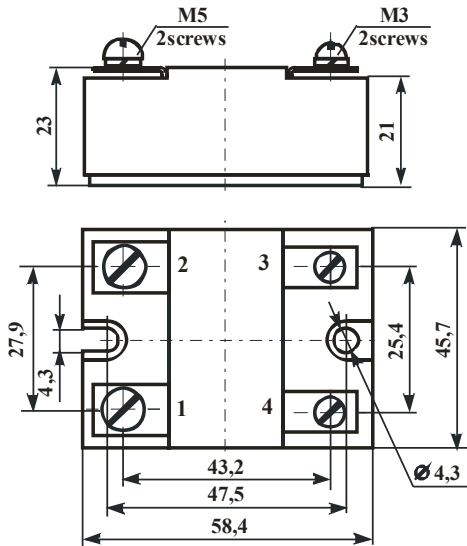

Figure 6.1 – Overall drawing of modules MT14, MT15D with maximum current up to 80 A

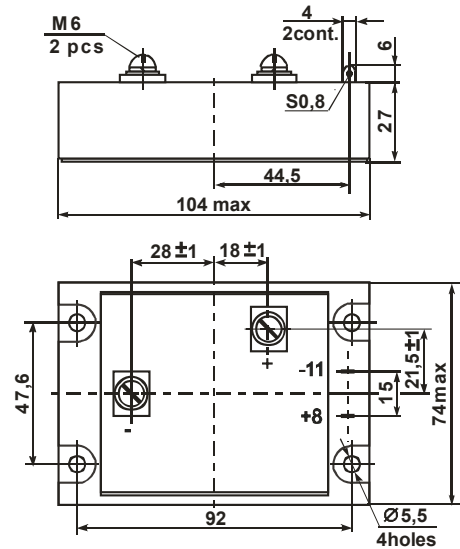

Figure 6.2 – Overall drawing of modules MT14, MT15D with maximum current 120, 160 A

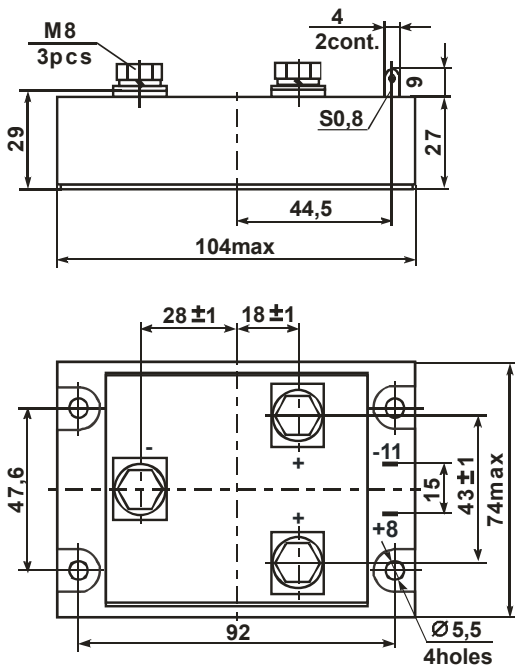

Figure 6.3 – Overall drawing of modules MT14, MT15D with maximum current 200, 240 A

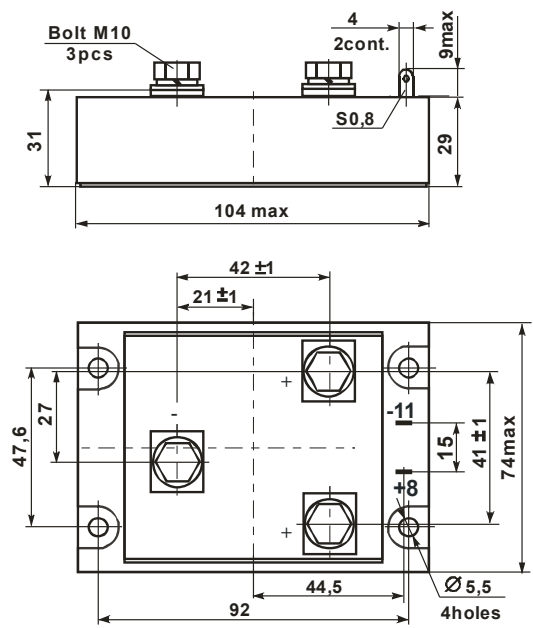

Figure 6.4 – Overall drawing of modules MT14, MT15D with maximum current 300, 400 A

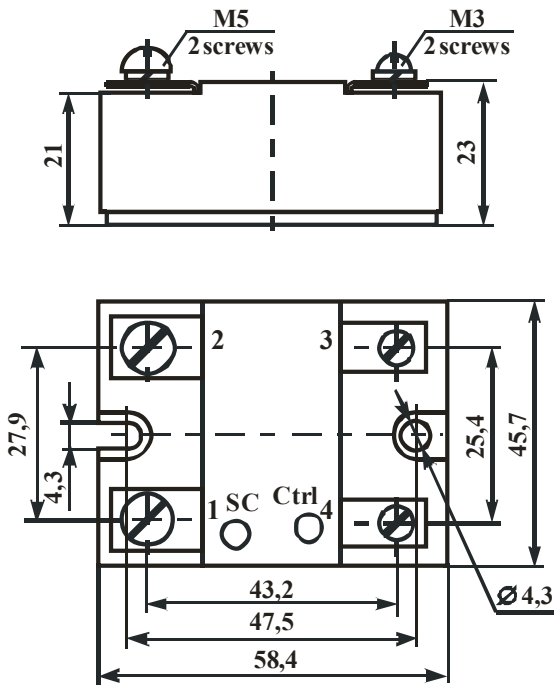

Figure 6.5 – Overall drawing of modules MT14PT, MT15PT with maximum current up to 80 A

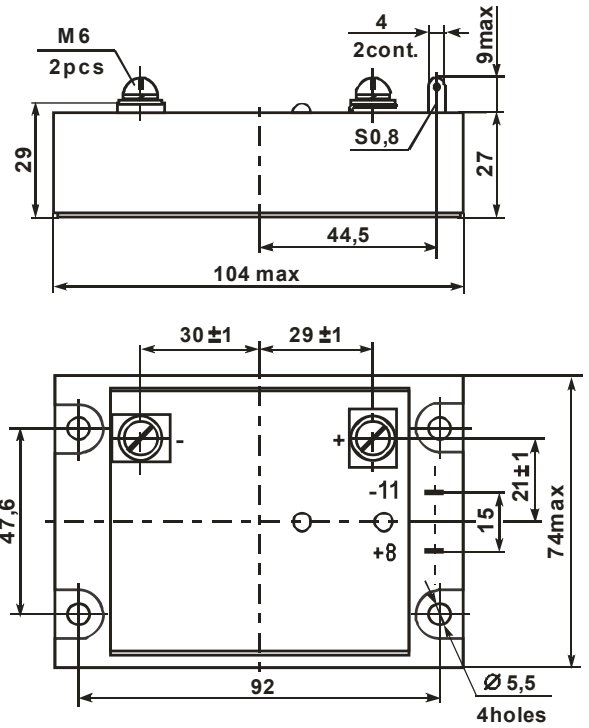

Figure 6.6 – Overall drawing of modules MT14PT, MT15PT with maximum current up to 160 A

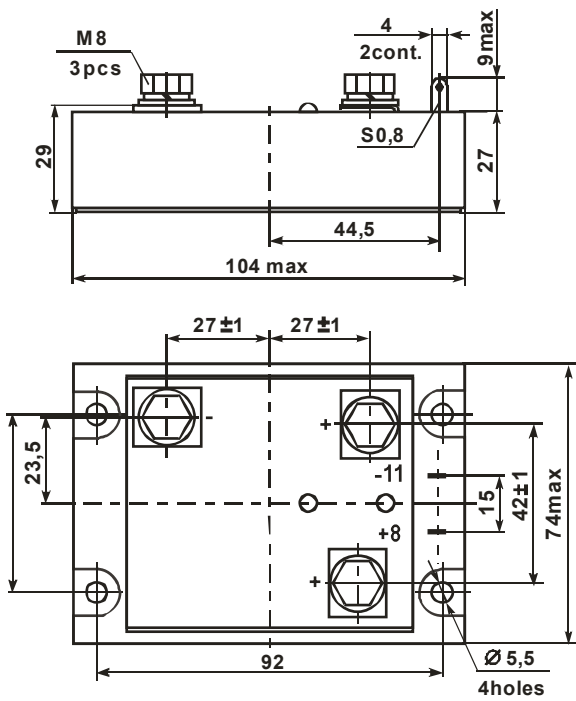

Figure 6.7 – Overall drawing of modules MT14PT, MT15PT with maximum current 180, 240 A

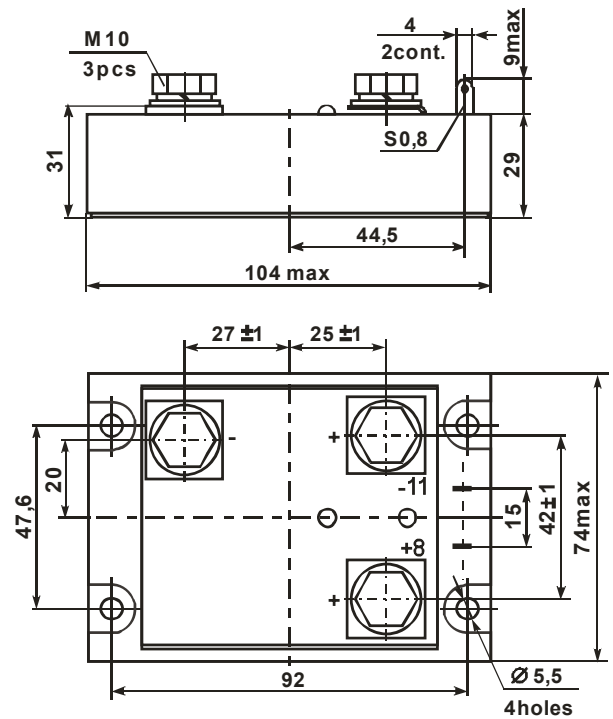

Figure 6.8 – Overall drawing of modules MT14PT, MT15PT with maximum current 320, 400 A

Precious metals are not contained.

COMPACT MODULES FOR DC COMMUTATION MT14, MT15D, MT14PT, 2MT14PT, MT15PT

1. APPLICATION AND PRODUCED MODULES

Compact modules for DC commutation (semiconductor normally opened unipolar relay with transformer decoupling with low current and low switch-on time) of types MT14, MT15D, MT14PT, 2MT14PT, MT15PT are intended to use in automatics devices as a commutating element with maximum peak voltage up to 1200 V and DC up to 10 A.

By the control types all the modules have the version «A» (control voltage 4...10 V) or «B» (control voltage 10...30 V).

The mark «PT» specified in the module's name shows the presence of inbuilt protection against overcurrent.

The modules for DC commutation (hereinafter - modules) are represented with the following versions:

MT14A(B)-PP1 – a module based on MOSFET-transistor shunted with a reverse fast-recovery diode in a housing corresponding to Fig. 6.1.

By the power switch types the modules are represented with the following versions (specified maximum permissible values of currents and voltages):

Peak voltage 100 V with DC 5 A.

Peak voltage 200 V with DC 5 A.

Peak voltage 400 V with DC 2.5 or 5 A.

Peak voltage 800 V with DC 5 A.

MT14A(B)-PP2 – a module based on MOSFET-transistor shunted with a reverse fast-recovery diode in a housing corresponding to Fig. 6.2.

By the power switch types the modules are represented with the following versions (specified maximum permissible values of currents and voltages):

Peak voltage 100 V with DC 5 A.

Peak voltage 200 V with DC 5 A.

Peak voltage 400 V with DC 2.5 or 5 A.

Peak voltage 800 V with DC 5 A.

MT14A(B)-PP6 – a module based on MOSFET-transistor shunted with a reverse fast-recovery diode in a housing corresponding to Fig.6.6.

By the power switch types the modules are represented with the following versions (specified maximum permissible values of currents and voltages):

Peak voltage 100 V with DC 2.5 A.

Peak voltage 200 V with DC 2.5 A.

MT15DA(B)-PP1 – a module based on IGBT-transistor shunted with a reverse fast-recovery diode in a housing corresponding to Fig.6.1.

By the power switch types the modules are represented with the following versions (specified maximum permissible values of currents and voltages):

Peak voltage 600 V with DC 2.5 A.

Peak voltage 1200 V with DC 2.5 A.

MT15DA(B)-PP6 – a module based on IGBT-transistor shunted with a reverse fast-recovery diode in a housing corresp. to Fig.6.6.

By the power switch types the modules are represented with the following versions (specified maximum permissible values of currents and voltages):

Peak voltage 600 V with DC 2.5 A.

Peak voltage 1200 V with DC 2.5 A.

MT14PTA(B)-PP1 – a module based on MOSFET-transistor shunted with a reverse fast-recovery diode in a housing corresp. to Fig.6.1 with inbuilt protection circuits.

By the power switch types the modules are represented with the following versions (specified maximum permissible values of currents and voltages):

Peak voltage 60 V with DC 5 A.

Peak voltage 100 V with DC 2.5 or 5 A.

Peak voltage 200 V with DC 2.5 or 5 A.

Peak voltage 400 V with DC 2.5 A.

MT14PTA(B)-PP2 – a module based on MOSFET-transistor shunted with a reverse fast-recovery diode in a housing corresp. to Fig.6.2 with inbuilt protection circuits.

By the power switch types the modules are represented with the following versions (specified maximum permissible values of currents and voltages):

Peak voltage 60 V with DC 5 A.

Peak voltage 100 V with DC 2.5 or 5 A.

Peak voltage 200 V with DC 2.5 or 5 A.

Peak voltage 400 V with DC 2.5 A.

MT14PTA(B)-PP3 – a module based on MOSFET-transistor shunted with a reverse fast-recovery diode in a housing corresp. to Fig.6.3 with inbuilt protection circuits.

By the power switch types the modules are represented with the following versions (specified maximum permissible values of currents and voltages):

Peak voltage 60 V with DC 10 A.

Peak voltage 100 V with DC 10 A.

Peak voltage 200 V with DC 8 A.

Peak voltage 400 V with DC 5 A.

2MT14PTA(B)-PP4 – a module based on MOSFET-transistor shunted with a reverse fast-recovery diode in a housing corresp. to Fig.6.4 with inbuilt protection circuits.

By the power switch types the modules are represented with the following versions (specified maximum permissible values of currents and voltages):

Peak voltage 60 V with DC 5 A.

Peak voltage 100 V with DC 2.5 or 5 A.

Peak voltage 200 V with DC 2.5 or 5 A.

Peak voltage 400 V with DC 2.5 A.

2MT14PTA(B)-PP5 – a module based on MOSFET-transistor shunted with a reverse fast-recovery diode in a housing corresp. to Fig.6.5 with inbuilt protection circuits.

By the power switch types the modules are represented with the following versions (specified maximum permissible values of currents and voltages):

Peak voltage 60 V with DC 10 A.

Peak voltage 100 V with DC 10 A.

Peak voltage 200 V with DC 8 A.

Peak voltage 400 V with DC 5 A.

MT15PTA(B)-PP1 – a module based on IGBT-transistor shunted with a reverse fast-recovery diode in a housing corresp. to Fig.6.1 with inbuilt protection circuits.

By the power switch types the modules are represented with the following versions (specified maximum permissible values of currents and voltages):

Peak voltage 600 V with DC 2 A.

Peak voltage 1200 V with DC 2 A.

MT15PTA(B)-PP2 – a module based on IGBT-transistor shunted with a reverse fast-recovery diode in a housing corresp. to Fig.6.2 with inbuilt protection circuits.

By the power switch types the modules are represented with the following versions (specified maximum permissible values of currents and voltages):

Peak voltage 600 V with DC 2 A.

Peak voltage 1200 V with DC 2 A.

MT15PTA(B)-PP3 – a module based on IGBT-transistor shunted with a reverse fast-recovery diode in a housing corresp. to Fig.6.3 with inbuilt protection circuits.

By the power switch types the modules are represented with the following versions (specified maximum permissible values of currents and voltages):

Peak voltage 600 V with DC 4 A.

Peak voltage 1200 V with DC 4 A.

Depending on the current and version the modules MO16 are produced in the versions that are represented in Table 1.1. The modules are produced only in the versions where at crossing the class line (peak voltage of power switch, maximum permissible one) of the module and the current column is specified the overall dimension corresponding to the version.

Table 1.1 – Produced modules MT14, 15 and corresponding to them overall dimensions

Type	Class	Current, A					
		2	2.5	4	5	8	10
MT14A(B)-PP1	1				Fig.6.1		
	2				Fig.6.1		
	4		Fig.6.1		Fig.6.1		
	8				Fig.6.1		
MT14A(B)-PP2	1				Fig.6.2		
	2				Fig.6.2		
	4		Fig.6.2		Fig.6.2		
	8				Fig.6.2		
MT14A(B)-PP6	1		Fig.6.6				
	2		Fig.6.6				
MT15DA(B)-PP1	6		Fig.6.1				
	12		Fig.6.1				
MT15DA(B)-PP6	6		Fig.6.6				
	12		Fig.6.6				
MT14PTA(B)-PP1	0,6				Fig.6.1		
	1		Fig.6.1		Fig.6.1		
	2		Fig.6.1		Fig.6.1		
	4		Fig.6.1				
MT14PTA(B)-PP2	0,6				Fig.6.2		
	1		Fig.6.2		Fig.6.2		
	2		Fig.6.2		Fig.6.2		
	4		Fig.6.2				
MT14PTA(B)-PP3	0,6						Fig.6.3
	1						Fig.6.3
	2					Fig.6.3	
	4				Fig.6.3		
2MT14PTA(B)-PP4	0,6				Fig.6.4		
	1		Fig.6.4		Fig.6.4		
	2		Fig.6.4		Fig.6.4		
	4		Fig.6.4				
2MT14PTA(B)-PP5	0,6						Fig.6.5
	1						Fig.6.5
	2					Fig.6.5	
	4				Fig.6.5		
MT15PTA(B)-PP1	6	Fig.6.1					
	12	Fig.6.1					
MT15PTA(B)-PP2	6	Fig.6.2					
	12	Fig.6.2					
MT15PTA(B)-PP3	6			Fig.6.3			
	12			Fig.6.3			

On Figure 1.1 is shown modules' names explanation.

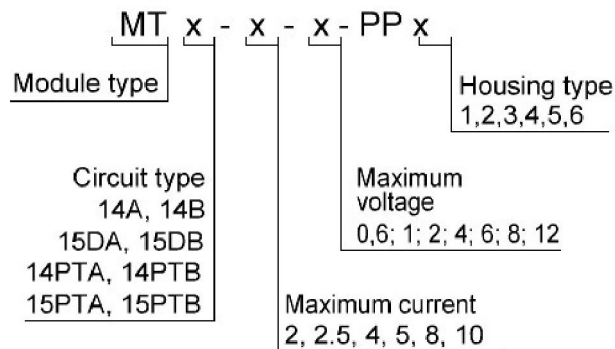

Figure 1.1 – Modules names explanation

For example, module MT14A-5-1-PP2: a module with control voltage 4...10 V, with maximum permissible drain-source voltage 100 V and maximum DC 5 A.

2. GENERAL DESCRIPTION

Functional circuits combined with switching circuits of modules MT14, 15 are represented on Figures 2.1 - 2.6.

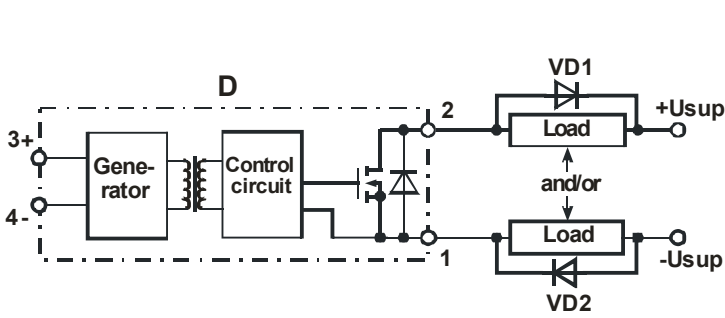
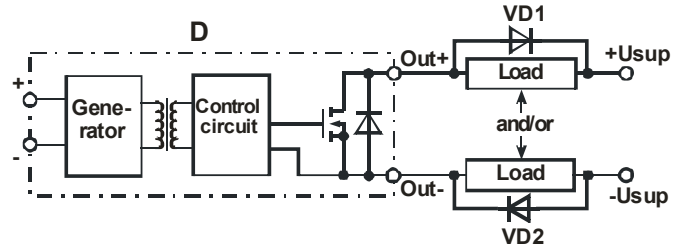

Figure 2.1 – Functional circuit MT14A(B)-PP1, MT14A(B)-PP2 (figure 6.1,2)



Contacts assignment:

- 1, 2, 3, 4 – «Out-»;
- 5 – «-»;
- 7, 8, 9, 10 – «Out+»;
- 6 – «+»

Figure 2.2 – Functional circuit MT14A(B)-PP6 (figure 6.6)

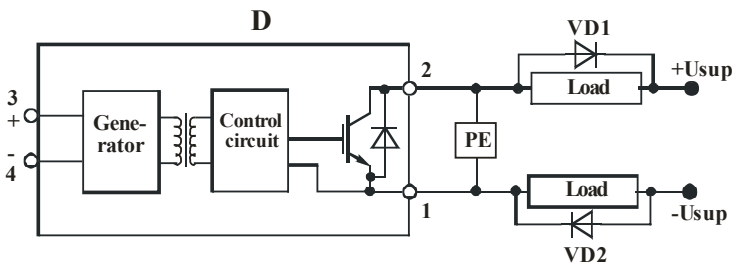
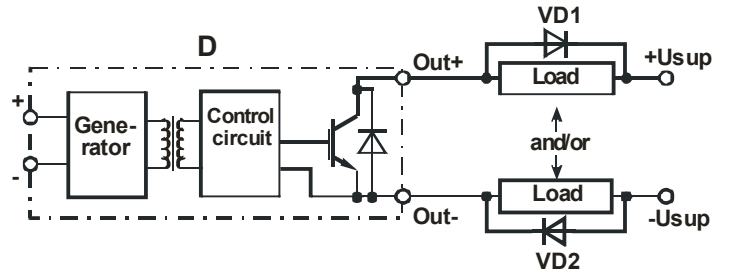

Figure 2.3 – Functional circuit MT15DA(B)-PP1 (figure 6.1)



Contacts assignment:

- 1, 2, 3, 4 – «Out-»;
- 5 – «-»;
- 7, 8, 9, 10 – «Out+»;
- 6 – «+»

Figure 2.4 – Functional circuit MT15DA(B)-PP6 (figure 6.6)

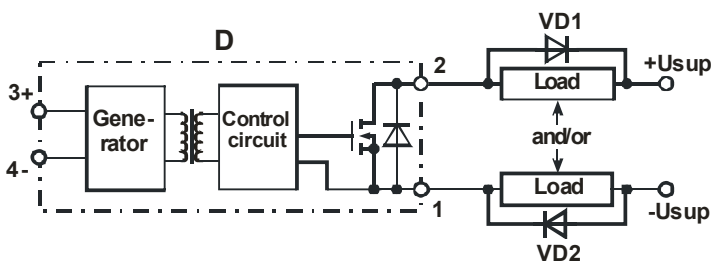

In MT15PTA(B) instead of MOSFET-transistors are installed IGBT-transistors with a similar control circuit (drain-source correspond to collector-emitter)

Figure 2.5 – Functional circuit MT14PTA(B)-PP1, MT14PTA(B)-PP2, MT14PTA(B)-PP3, MT15PTA(B)-PP1, MT15PTA(B)-PP2, MT15PTA(B)-PP3 (fig.6.1,2,3)

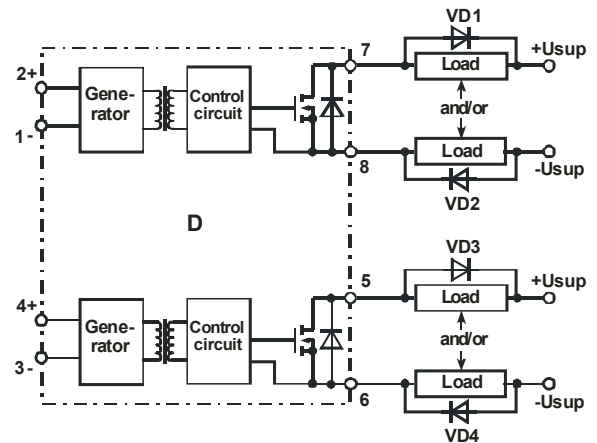

Figure 2.6 – Functional circuit 2MT14PTA(B)-PP4, 2MT14PTA(B)-PP5 (figure 6.4,5)

Where D – module; PE – protection element; VD1,VD2 – diodes (are installed at inductive load).

The modules MT14, MT15D don't have any inbuilt protections; the relays operate in accordance with the control signal only.

The modules MT14(15)PTA и MT14(15)PTB have a inbuilt protection against overcurrent. The protection against overcurrent is represented a pick-up resistor that installed in the power circuit, also represented comparison circuit and reset circuit. When the current exceeds the set threshold during more than 10 μ s the control circuit cuts off the transistor for 100 ms (it depends on the value of current exceeding), after that the transistor opens again and if the overload was not eliminated then the cycle repeats.

3. BASIC PARAMETERS

Basic parameters and maximum permissible parameters of the modules at temperature 25 $^{\circ}$ C are shown in Tables 3.1 – 3.5.

Table 3.1 – Basic and maximum permissible control parameters of modules MT14, MT15

Parameter name, unit	Symbol	MT14	MT15D	MT14PT	MT15PT
Input current of ver. «A» at $U_{IH} = 4$ V (max), mA	I_{IN}	7	7	25	25
Input current of ver. «A» at $U_{IH} = 10$ V (max), mA		15	15	30	30
Input current of ver. «B» at $U_{IH} = 10$ V (max), mA		15	15	30	30
Input current of ver. «B» at $U_{IH} = 30$ V (max), mA		20	20	40	40
Switch-on voltage of ver. «A», V	U_{IH}	4...10			
Switch-on voltage of ver. «B», V		10...30			
Switch-off voltage of ver. «A», V	U_{IL}	-3.5...0.8			
Switch-off voltage of ver. «B», V		-3.5...0.8			
On / off duration (max), μ s	$t_{on/off}$	50 / 50	50 / 50	100 / 100	100 / 100

Table 3.2 – Basic parameters of current protection of modules MT14PT, MT15PT

Parameter name, unit	Symbol	Value	Notes
Current protection operation delay (max), μ s	t_{CP}	10	
Blocking duration when operating of current protection (typ.), ms	t_B	100	
Current of protection operation against current overload (typ.), A	I_{CP}	For modules with maximum current:	
		3	2
		3.8	2.5
		6	4
		7.5	5
		12	8
		15	10

Table 3.3 – Basic and maximum permissible parameters of modules of 0,6 and 1 classes

Parameter name, unit	Symbol	Power assembly type (current-class)				
		5-0,6	10-0,6	2,5-1	5-1	10-1
Drain-source voltage (max), V	V_{DSS}	60		100		
Direct voltage of power circuit (max), V	V_{DC}	35		60		
DC of power circuit (max), A	I_{DC}	5	10	2.5	5	10
Pulse current of power circuit (max), A	I_P	15	30	7.5	15	30
Drain-source resistance in open state (max), mΩ	$R_{DS(on)}$	60	60	36	36	36
Direct voltage fall on reverse diode (max), V	V_F	1.3				
Leakage current of power switch (max), μA	I_{DSS}	100				
Junction temperature (max), °C	T_j	150				
Junction-base thermal resistance (max), °C/W	$R_{th(j-a)}$	40 (2.7) *				
Insulation strength, (DC), V	V_{ISOL}	1000				

Table 3.4 – Basic and maximum permissible parameters of modules of 2, 4, 8 classes

Parameter name, unit	Symbol	Power assembly type (current-class)					
		2,5-2	5-2	8-2	2,5-4	5-4	5-8
Drain-source voltage (max), V	V_{DSS}	200			400		800
Direct voltage of power circuit (max), V	V_{DC}	130			250		500
DC of power circuit (max), A	I_{DC}	2.5	5	8	2.5	5	5
Pulse current of power circuit (max), A	I_P	7.5	14	24	7.5	15	15
Drain-source resistance in open state (max), mΩ	$R_{DS(on)}$	180	23	23	200	200	300
Direct voltage fall on reverse diode (max), V	V_F	1.3					
Leakage current of power switch (max), μA	I_{DSS}	100					
Junction temperature (max), °C	T_j	150					
Junction-base thermal resistance (max), °C/W	$R_{th(j-a)}$	40 (2.7) *					
Insulation strength, (DC), V	V_{ISOL}	1000			4000		

Table 3.5 – Basic and maximum permissible parameters of modules of 6, 12 classes

Parameter name, unit	Symbol	Power assembly type (current-class)					
		2-6	2,5-6	4-6	2-12	2,5-12	4-12
Collector-emitter voltage (max), V	V_{CES}	600			1200		
Direct voltage of power circuit (max), V	V_{DC}	350			650		
DC of power circuit (max), A	I_{DC}	2	2.5	4	2	2.5	4
Pulse current of power circuit (max), A	I_P	6	7.5	12	6	7.5	12
Collector-emitter saturation voltage (max), V	$V_{CE(on)}$	3.0					
Direct voltage fall on reverse diode (max), V	V_F	2.5					
Leakage current of power switch (max), μA	I_{CES}	250					
Junction temperature (max), °C	T_j	150					
Junction-base thermal resistance (max), °C/W	$R_{th(j-a)}$	40 (2.7) *					
Insulation strength, (DC), V	V_{ISOL}	4000					

* - in the brackets shown the value for housings of types PP3 and PP5

4. INSTRUCTIONS FOR USE

General requirements

It is recommended to operate the module at operating value of the average current not more than 80% from specified one in the name of the module and the junction temperature not more than (70÷80)% from the maximum one.

It is not allowed to operate the module in modes at simultaneous influence of two or more maximum permissible values.

In the electric circuit of equipment with using of the modules should be provided the fast-speed protection against prohibitive overloads, SCs and commutating overloads.

Module mounting

The module is mounted in the equipment to cooler (chassis, application housing, metal plates, etc.) in any orientation with screws M4 with torque (5 ± 0.5) N·m, with obligatory installation of flat and spring washers. The module should be located in such a way to protect it against additional heat from neighbor elements. The planes of cooler ribs should be oriented in the direction of air flow.

The contact area of the cooler should have roughness not more than $2.5\ \mu\text{m}$ and flatness tolerance – not more than $30\ \mu\text{m}$. Cooler surface should not have any rough edges, honeycombs. There should not be extraneous particles between the module and cooler. To improve the heat balance the module installation to mounting area or cooler should be carried out by instrumentality of heat conducting pastes or having similar heat conducting properties.

When mounting, you should provide uniform pressure of module housing to cooler. For this purpose you should tighten all screws uniform in 2 – 4 steps by turns: first, located on one diagonal, then on the other one. When dismantling the module the screw tightening should be done in the reverse order.

Not earlier than in 3 hours after mounting the screws should be rotated to the end, keeping the prescribed torque, because the part of heat conducting paste under pressure will outflow and the fastening can fail.

You can mount the several modules without additional insulating spacer to one cooler, on condition that voltage between outputs of different modules will not exceed the minimum value of isolation breakdown voltage of each of them or when cooler is grounded.

The modules PP1, PP2, PP4, and PP6 are not intended for mounting on the cooler.

Connection to module

The controlling module outputs are intended for mounting in equipment by means of soldering or split connectors. Permissible number of module outputs' re-soldering during electronic (assembly) edit is three. Outputs soldering should be performed at temperature not higher than (235 ± 5) °C. Soldering duration is not longer than 3 sec.

When mounting and operating it is necessary to make protection measures against static electricity impact and overvoltage in gate circuit; on mounting personnel should use a ground band and grounded low-voltage soldering irons with transformer supply.

Operation requirements

The module should be used under mechanical loads in accordance with Table 4.1.

Table 4.1 – Mechanical loads impact

External exposure factor	External exposure factor value
Sinusoidal vibration: - acceleration, m/s ² (g); - frequency, Hz	150 (15) 0.5 - 100
Multiple-acting mechanic shock: - peak shock acceleration, m/s ² (g); - shock acceleration duration, ms	40 (4) 50
Linear acceleration, m/s ² (g)	5000 (500)

The module should be used under climatic loads in accordance with Table 4.2.

Table 4.2 – Climatic loads impact

Climatic factor	Climatic factor value
Reduced ambient temperature: - operating, °C; - maximum, °C	- 40 - 45
High ambient temperature: - operating, °C; - maximum, °C	+ 85 + 100
Relative humidity at temperature 35 °C without moisture condensation, %, max	98

Safety requirements

1. Working with the module should only be performed by qualified personnel.
2. Do not touch the power terminals of the module when applying a voltage.
3. Do not connect or disconnect wires and connectors while the power to the circuit module is applying a voltage.
4. Do not touch the module radiator, if it is not grounded in and is applying a voltage on it.
5. Do not touch the cooler and the module housing during its operation, since their temperature can be very high.
6. Immediately turn off the power supply of the module if it discharges smoke, odor or abnormal noises, check if the module correctly connected.
7. It is not allowed to penetrate water and other liquids to the module.

5. RELIABILITY REQUIREMENTS

The manufacturer guarantees the quality of the module all the requirements of the user's manual passport if the consumer observes terms and conditions of storage, installation and operation, as well as guidance on the application specified in the user's manual.

Operating warranty is two years from the acceptance date, in case of requalification – from the date of the requalification.

Reliability probability of the module for 25000 hours must be at least 0.95.

Gamma percentage life (T_γ) of module at $\gamma = 90\%$ in typical operation conditions should not be less than 50 000 hours within lifetime.

Gamma-percent service life of the modules, subject to cumulative operating time is not more than gamma-percent life, not less than 10 years, at $\gamma = 90\%$.

Gamma-percent storageability time of the modules, at $\gamma = 90\%$ and storing – 10 years.

6. OVERALL AND CONNECTING DIMENSIONS

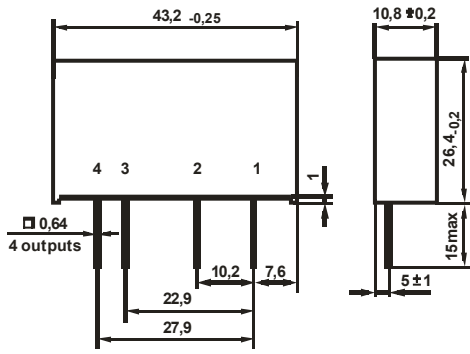

Figure 6.1 – Overall drawing of modules with ver. PP1

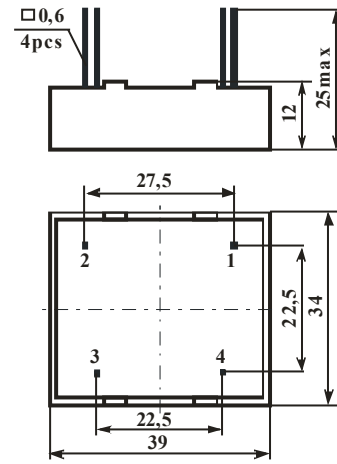

Figure 6.2 - Overall drawing of modules with ver. PP2

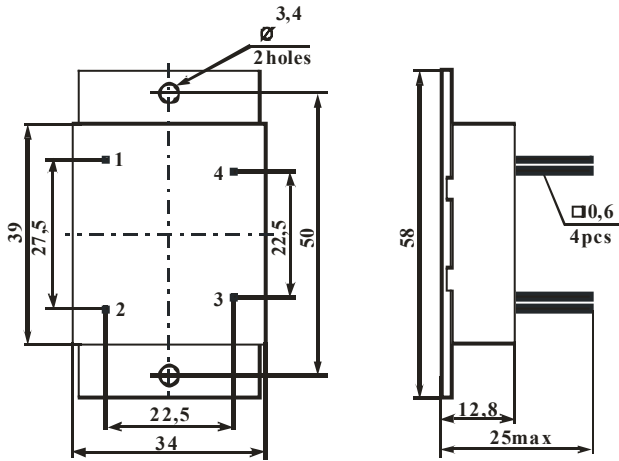

Figure 6.3 - Overall drawing of modules with ver. PP3

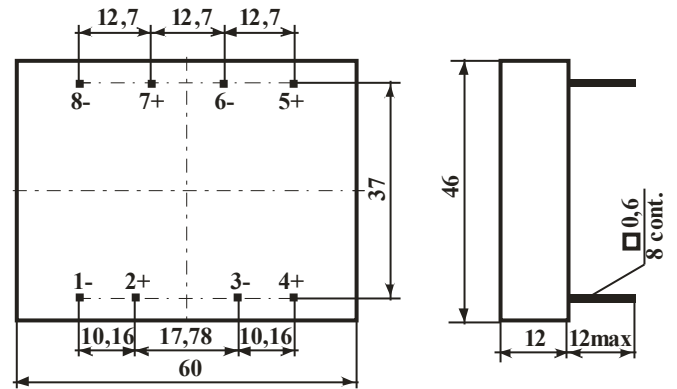

Figure 6.4 - Overall drawing of modules with ver. PP4

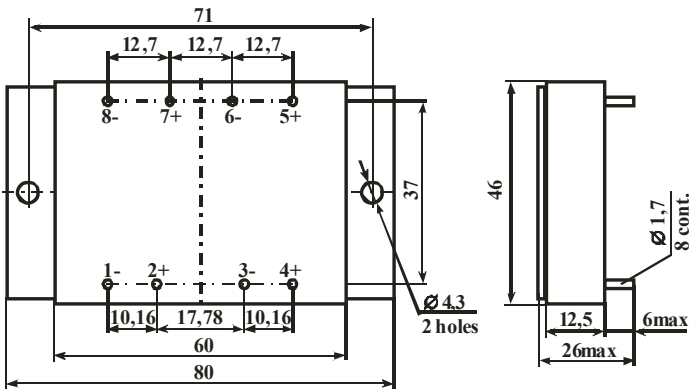

Figure 6.5 - Overall drawing of modules with ver. PP5

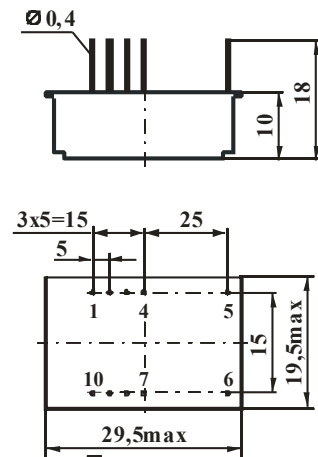

Figure 6.6 – Overall drawing of modules with ver. PP6

По вопросам продаж и поддержки обращайтесь:

Архангельск +7 (8182) 45-71-35
 Астрахань +7 (8512) 99-46-80
 Барнаул +7 (3852) 37-96-76
 Белгород +7 (4722) 20-58-80
 Брянск +7 (4832) 32-17-25
 Владивосток +7 (4232) 49-26-85
 Волгоград +7 (8442) 45-94-42
 Екатеринбург +7 (343) 302-14-75
 Ижевск +7 (3412) 20-90-75
 Казань +7 (843) 207-19-05
 Калуга +7 (4842) 33-35-03

Кемерово +7 (3842) 21-56-70
 Киров +7 (8332) 20-58-70
 Краснодар +7 (861) 238-86-59
 Красноярск +7 (391) 989-82-67
 Курск +7 (4712) 23-80-45
 Липецк +7 (4742) 20-01-75
 Магнитогорск +7 (3519) 51-02-81
 Москва +7 (499) 404-24-72
 Мурманск +7 (8152) 65-52-70
 Наб. Челны +7 (8552) 91-01-32
 Ниж.Новгород +7 (831) 200-34-65

Новосибирск +7 (383) 235-95-48
 Омск +7 (381) 299-16-70
 Орел +7 (4862) 22-23-86
 Оренбург +7 (3532) 48-64-35
 Пенза +7 (8412) 23-52-98
 Пермь +7 (342) 233-81-65
 Ростов-на-Дону +7 (863) 309-14-65
 Рязань +7 (4912) 77-61-95
 Самара +7 (846) 219-28-25
 Санкт-Петербург +7 (812) 660-57-09
 Саратов +7 (845) 239-86-35

Сочи +7 (862) 279-22-65
 Ставрополь +7 (8652) 57-76-63
 Сургут +7 (3462) 77-96-35
 Тверь +7 (4822) 39-50-56
 Томск +7 (3822) 48-95-05
 Тула +7 (4872) 44-05-30
 Тюмень +7 (3452) 56-94-75
 Ульяновск +7 (8422) 42-51-95
 Уфа +7 (347) 258-82-65
 Хабаровск +7 (421) 292-95-69
 Челябинск +7 (351) 277-89-65
 Ярославль +7 (4852) 67-02-35